

Drum Blower WDH-TG105L



Dear Customer,

You have chosen a high-quality product. To ensure that you get a lot of enjoyment from this product, here are a few more tips:

In case of any problems:

We hope that the unit meets your expectations! If, despite the greatest possible care, there should ever be cause for complaint, please contact us briefly, as we are very concerned about your satisfaction and would like to clear up any misunderstanding.

Description:

This drum blower is very robustly manufactured and designed for a long service life. It produces a very high air flow rate with relatively low power consumption. The entire unit and the rotor are made of metal. The blower has two speed levels, castors and two practical handles. Furthermore, the unit is equipped with an overheating protection and works with a long-lasting high-performance motor.

Important safety instructions:

- This drum blower must not be exposed to direct moisture (rain) !
- Do not operate the unit in environments where there is a risk of coarse dust, dirt or small objects being sucked in. These could damage the unit or be blown out like projectiles !
- Never walk with your head/face into the near area of the escaping wind stream, small particles or objects can be blown out with it, which can lead to injuries !
- Ensure that the blower stands securely and level !
- Never use the blower on moving surfaces, objects or vehicles ! There is a risk that the unit may tip over !
- Supervise the fan when children are near the unit !
- This appliance is not intended to be used by persons (including children) with reduced physical, sensory or mental capabilities, or lack of experience and/or knowledge, unless they have been given supervision or instruction concerning use of the appliance by a person responsible for their safety.
- Never enter or insert objects into the appliance !
- Never try to touch the moving rotor blades !
- Do not place any objects on the fan !
- Do not block the supply and/or exhaust air of the unit and please ensure sufficient space/clearance around the unit !
- Ensure that there is sufficient air supply to the unit, otherwise it can lead to a reduction in performance and, in the worst case, to overheating and/or fire !
- Only qualified personnel or electricians are allowed to open the unit !
- Only use the recommended voltage for operating the unit !
- Make sure that the power cable is unfolded (untied) before connecting it to the socket !
- Make sure that the plug is cleanly and properly connected to the socket before using the appliance !
- Never reach near the plug or socket with wet hands !
- Do not repair defective or damaged cables on the unit yourself, you could get a severe electric shock !
- Make sure that highly flammable substances (e.g. gases/oils etc.) are never in the vicinity of the unit !
- If you are not going to use the unit for a long time, switch it off and disconnect the mains plug !

Please switch off the unit immediately and disconnect it from the mains/power supply if anything seems to be wrong !!! In this case, please contact a specialist and do not try to repair the unit yourself !!!

Examples: Fan does not run during operation or fuse has blown.

Instructions for use:

1. Operational environment

- The maximum operating temperature should not exceed +40°C !
- The unit should not be operated at altitudes higher than 1,000 metres above sea level !

2. Commissioning

- 2.1. Position the blower so that the air stream flows in the desired direction after switching on. When doing so, please note that the front (exhaust air) of the blower is identified by the trademark. The on/off switch is located above the blower drum.

Adjustment of the air flow:

The fan head can be swivelled from top to bottom and thus the air flow can be tilted in any desired direction. To change the airflow in a desired lateral direction, it is sufficient to slightly change or adjust the standing position of the unit.

- 2.2. Now insert the mains plug properly into the socket.

- 2.3. The fan is switched on by a rotary switch located on top of the drum of the unit. Point the rotary switch in the direction of the arrow to the desired operating position.

- 0** = OFF
- 1** = ON in weak fan stage
- 2** = ON in strong fan stage

3. Maintenance, Cleaning & Storage

Please always disconnect the mains plug first and allow the fan to run down completely before carrying out any cleaning activities on your appliance !

3.1. Maintenance:

A professional should treat the blower axle with lubricating oil approx. every 1,500 operating hours to ensure optimum operation and a long blower service life.

3.2 Cleaning:

- Use a soft and damp cloth to clean the outside of the unit.
- Only use mild cleaning agents to clean your blower.
- Please make sure that water does not get inside the motor or the electrical control box at any time !
- Be careful not to accidentally adjust (bend) the angle of the rotor blades when cleaning the unit.

3.3 Storage:

- We recommend that you cover the unit for storage or, ideally, pack it in its original box.
- Store the unit in a dry and sufficiently ventilated place/space.

4. Other operating instructions

- 4.1. Do not disconnect the mains plug by pulling on the power cable !
- 4.2. Do not use insect spray, oil spray, paint spray, etc. near the blower. This may cause damage to the unit or even fire !
- 4.3. Do not place the appliance on sloping or uneven ground !

Technical data:

Model name:	WDH-TG105L
Voltage:	220-240V / 50Hz
Max. Power consumption:	750 W (3.4 A)
Max. Air circulation:	13,022 m ³ /h
Protection class:	IP24
Diameter air duct:	Approx. 108 cm
Max. Speed:	1,039 rpm.
Max. Noise emission:	Approx. 75 dB
Dimension (H/W/D):	1,290 x 1,230 x 525 mm
Weight:	50 kg

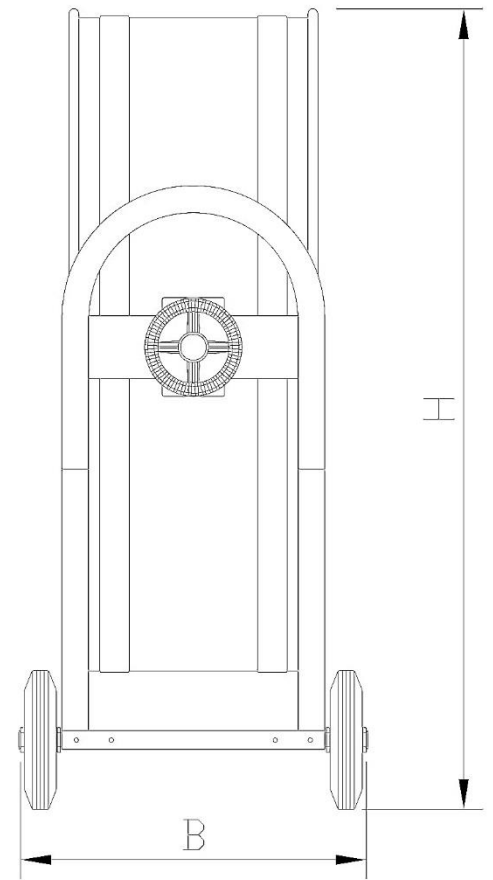
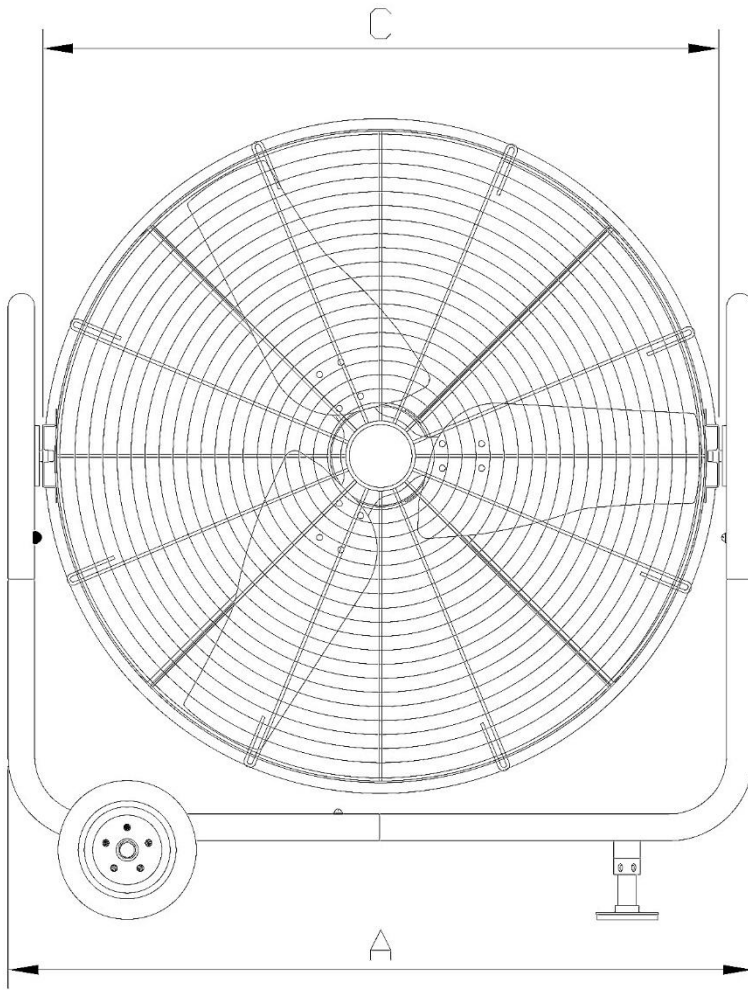

A	>	Total width	=	1,230 mm
B	>	Depth (total)	=	525 mm
C	>	Drum width	=	1,120 mm
H	>	Height (total)	=	1,290 mm

For the technical data, deviations are reserved !!!

Exploded view:

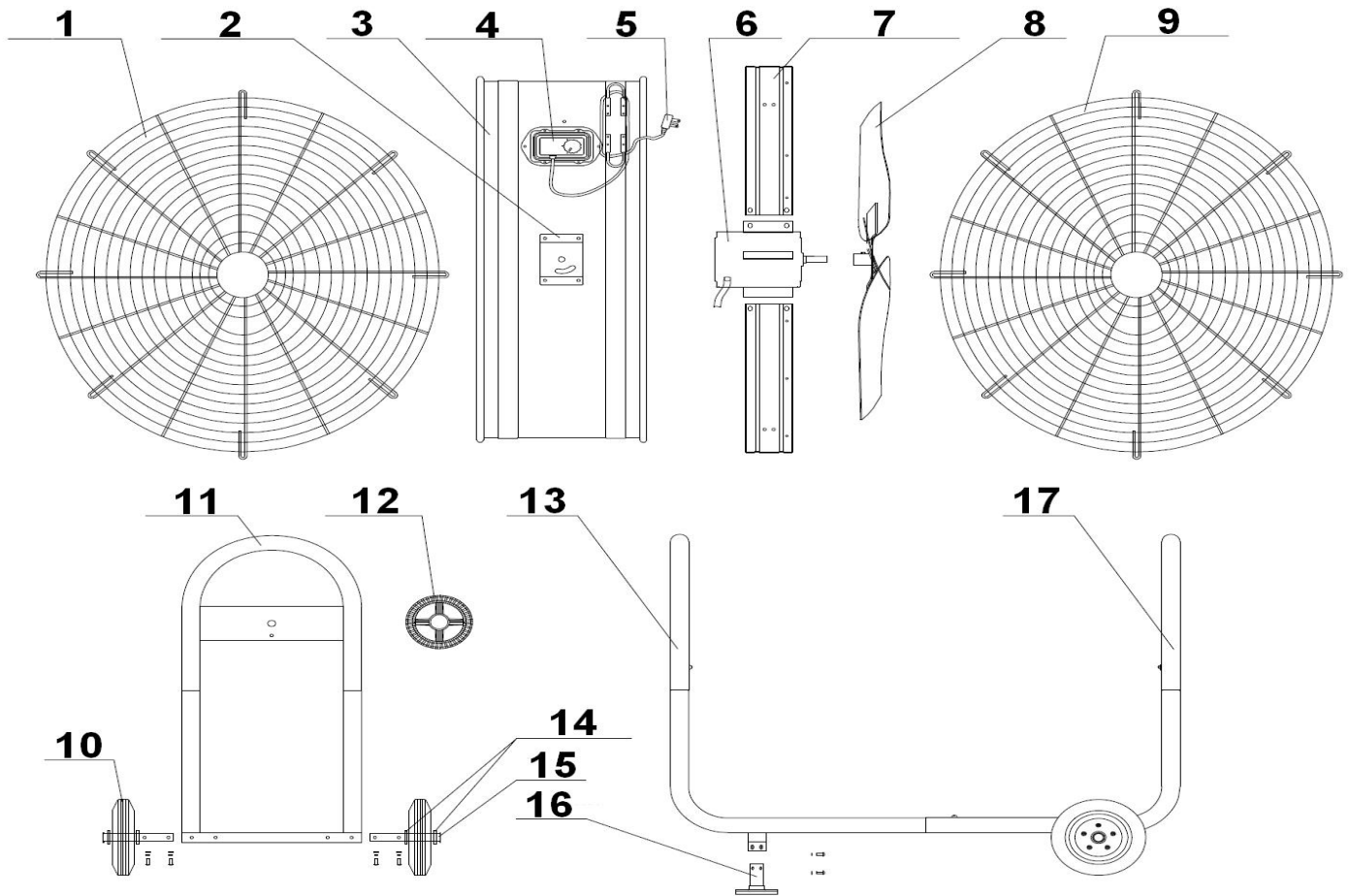

- 1) Protective grille rear
- 2) Adjustment plate
- 3) Drum
- 4) Control unit
- 5) Mains plug
- 6) Motor
- 7) Bracket arm (motor)
- 8) Rotor
- 9) Protective grille front

- 10) Castor
- 11) Handle
- 12) Locking wheel
- 13) Handle left
- 14) Axis clamp
- 15) Axle
- 16) Stand / support
- 17) Handle right

Other:

Warranty statement:

Notwithstanding the statutory warranty claims, the manufacturer grants a warranty in accordance with the laws of your country, but at least 1 year (in Germany 2 years for private individuals). The warranty begins on the date of sale of the appliance to the end user.

The guarantee only covers defects that are due to material or manufacturing faults.

Warranty repairs may only be carried out by an authorised customer service. To make a warranty claim, please enclose the original sales receipt (with date of sale).

Excluded from the guarantee are:

- Normal wear
- Improper applications, such as overloading the appliance or non-approved accessories.
- Damage due to external influences, use of force or foreign objects
- Damage caused by non-observance of the operating instructions, e.g. connection to an incorrect mains voltage or non-observance of the assembly instructions.
- Completely or partially dismantled units

Conformity:

The drum blower has been tested and itself and/or parts thereof have been manufactured under the following (safety) standards:

Of course with CE (EMC + LVD) conformity.

EMC conformity tested according to: EN IEC 55014-1:2021
EN IEC 55014-2:2021
EN IEC 61000-3-2:2019+A1:2021
EN 61000-3-3:2013+A1:2019

CE (LVD) Conformity tested according to: EN 60335-1:2012+A11:2014+A13:2017+A1:2019+A2:2019+A14:2019
+A15:2021
EN 60335-2-80:2003+A1:2004+A2:2009
EN 62233:2008

Correct disposal of this product:



Within the EU, this symbol indicates that this product should not be disposed of with household waste. Waste equipment contains valuable recyclable materials that should be recycled and not harm the environment or human health through uncontrolled waste disposal. Therefore, please dispose of old appliances via suitable collection systems or send the appliance for disposal to the place where you purchased it. They will then recycle the appliance.

We hope you enjoy using this appliance:

Your Aktobis AG

Keep these instructions for use in a safe place !